

FORK TYPE MIXER

USE

- FBL fork type fixed bowl mixers are designed for high output bakeries, and fit into all production lines
- Mixing quality: the geometry of the 2 rotation speed blade combined with the shape of the bowl, gives quality mixing in accordance with the principles of the main phases of cutting, stretching, aerating and piecing.

CONSTRUCTION

- 1 timer
- Epoxy painted frame (food-grade)
- Triangular section cast aluminium arm:
- 1 direction of rotation
- 2 mixing speeds
- Non powered stainless steel bowl with brake
- Raisable safety grids
- 24 V electronic control
- Three phase 400 V 50 Hz



FBL Standard

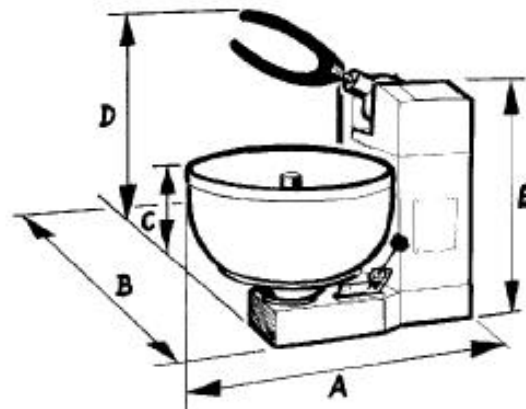

CAPACITY

Model	Flour	Dough	Pouring	Total
FBL 230	37 - 75 kg	59 - 120 kg	22 - 45 l	230 l
FBL 330	60 - 100 kg	96 - 160 kg	36 - 60 l	330 l

Model	Power 1st gear	Power 2nd gear	Internal diameter	Net weight
FBL 230	3.7 kW	5.5 kW	900 mm	540 kg
FBL 330	3.7 kW	5.5 kW	1000 mm	570 kg

DIMENSIONS

Model	A	B	C	D	E
FBL 230	1,465 mm	1,095 mm	840 mm	1,310 mm	1,300 mm
FBL 330	1,515 mm	1,145 mm	885 mm	1,420 mm	1,325 mm